

真空接头系列

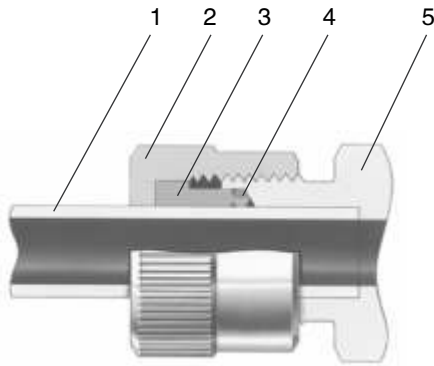

- 温度从20至204℃。
- 密封圈有NBR、FKM多种材产可选。
- 常温下最大泄露率为 4×10^{-9} std cm³/s。
- 尺寸为1/8in至1in、3mm至25mm。

真空管接头



结构材料

元件	材料
1 卡套管	不锈钢管/塑料管/玻璃管
2 真空接头螺母	316L
3 真空接头卡芯	316L
4 O型圈	丁腈橡胶/氟橡胶
5 接头体	316L

直通真空管接头

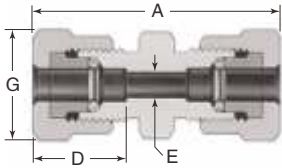

卡套管外径 in.	订购号	尺寸, in. (mm)			
		A	D	E	G
1/8	-U-ZKM2	1.40 (35.6)	0.43 (10.9)	0.09 (2.3)	9/16
1/4	-U-ZKM4	1.63 (41.4)	0.62 (15.7)	0.18 (4.6)	11/16
3/8	-U-ZKM6	1.81 (46.0)	0.66 (16.8)	0.28 (7.1)	13/16
1/2	-U-ZKM8	1.84 (46.7)	0.80 (20.3)	0.40 (10.2)	15/16
5/8	-U-ZKM10	1.84 (46.7)	0.84 (21.3)	0.50 (12.7)	1 1/8
3/4	-U-ZKM12	2.05 (52.1)	0.94 (23.9)	0.62 (15.7)	1 1/4
1	-U-ZKM16	2.15 (54.6)	0.94 (23.9)	0.87 (22.1)	1 9/16

变径真空管接头

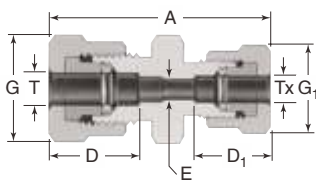

卡套管外径, in.		订购号	尺寸, in. (mm)					
T	T _x		A	D	D ₁	E	G	G ₁
3/8	1/4	-U-ZK6-ZK4	1.72 (43.7)	0.66 (16.8)	0.62 (15.7)	0.18 (4.6)	13/16	11/16
1/2		-U-ZK8-ZK4	1.75 (44.4)	0.80 (20.3)				

真空管弯头

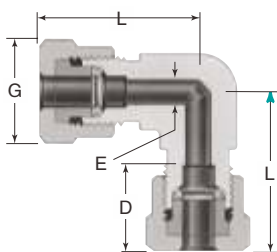

卡套管外径 in.	订购号	尺寸, in. (mm)			
		D	E	G	L
1/4	-L-ZK4	0.62 (15.7)	0.18 (4.6)	11/16	1.14 (29.0)
3/8	-L-ZK6	0.66 (16.8)	0.28 (7.1)	13/16	1.36 (34.5)
1/2	-L-ZK12	0.80 (20.3)	0.40 (10.2)	15/16	1.36 (34.5)

三通真空管接头

卡套管外径 in.	订购号	尺寸, in. (mm)				
		A	D	E	G	L
1/8	-T-ZK2	2.12 (53.8)	0.43 (10.9)	0.09 (2.3)	9/16	1.06 (26.9)
1/4	-T-ZK4	2.30 (58.4)	0.62 (15.7)	0.18 (4.6)	11/16	1.15 (29.2)
3/8	-T-ZK6	2.72 (69.1)	0.66 (16.8)	0.28 (7.1)	13/16	1.36 (34.5)
1/2	-T-ZK8	2.72 (69.1)	0.80 (20.3)	0.40 (10.2)	15/16	1.36 (34.5)
3/4	-T-ZK12	3.30 (83.8)	0.94 (23.9)	0.62 (15.7)	1 1/4	1.65 (41.9)
1	-T-ZK16	3.64 (92.4)	0.94 (23.9)	0.87 (22.1)	1 9/16	1.82 (46.2)

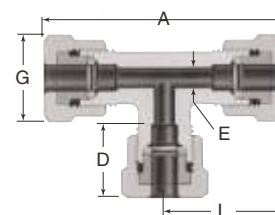

外螺纹真空管接头

卡套管 外径 in.	NPT 尺寸 in.	订购号	尺寸, in. (mm)				
			A	B	D	E	G
1/8	1/8	-U-ZK2-T2	1.22 (31.0)	0.38 (9.6)	0.43 (10.9)	0.09 (2.3)	9/16
1/4	1/8	-U-ZK4-T2	1.35 (34.3)	0.38 (9.6)	0.6 (15.7)	0.18 (4.6)	11/16
	1/4	-U-ZK4-T4	1.53 (38.9)	0.56 (14.2)			
3/8	1/8	-U-ZK6-T2	1.44 (36.6)	0.38 (9.6)	0.66 (16.8)	0.18 (4.6)	13/16
	1/4	-U-ZK6-T4	1.62 (41.1)	0.56 (14.2)		0.8 (7.1)	
1/2	3/8	-U-ZK8-T6	1.65 (41.9)	0.56 (14.2)	0.80 (20.3)	0.40 (10.2)	15/16
	1/2	-U-ZK8-T8	1.84 (46.7)	0.75 (19.1)			
3/4	3/4	-U-ZK12-T12	1.96 (49.8)	0.75 (19.1)	0.94 (23.9)	0.6 (15.7)	1 1/4
1	1	-U-ZK16-T16	2.25 (57.2)	0.94 (23.9)	0.94 (23.9)	0.87 (22.1)	1 9/16

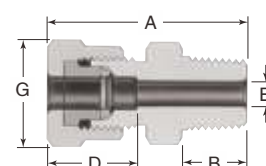

真空管接头转卡套

卡套管外径, in.		订购号	尺寸, in. (mm)				
T	Tx		A	D	D ₁	E	G
1/4	1/4	-U-C4-ZK4	1.66 (42.2)	0.62 (15.7)	0.60 (15.2)	0.18 (4.6)	11/16
3/8	3/8	-U-C6-ZK6	1.81 (46.0)	0.66 (16.8)	0.66 (16.8)	0.28 (7.1)	13/16
1/2	1/2	-U-C8-ZK8	1.95 (49.5)	0.80 (20.3)	0.90 (22.9)	0.40 (10.2)	15/16

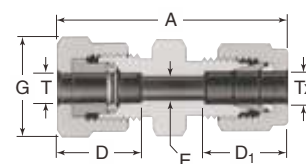

真空管接头转光管

卡套管外径, in.		订购号	尺寸, in. (mm)			
T	Tx		A	D	E	G
1/8	1/4	-U-ZK2-DWT4	1.20 (30.5)	0.43 (10.9)	0.09 (2.3)	9/16
	3/8	-U-ZK2-DWT6	1.21 (30.7)			
1/4	1/4	-U-ZK4-DWT4	1.34 (34.0)	0.62 (15.7)	0.18 (4.6)	11/16
	3/8	-U-ZK4-DWT6	1.33 (33.8)			
	1/2	-U-ZK4-DWT8	1.47 (37.3)			
3/8	3/8	-U-ZK6-DWT6	1.47 (37.3)	0.66 (16.8)	0.28 (7.1)	13/16
	1/2	-U-ZK6-DWT8	1.58 (40.1)			
1/2	5/8	-U-ZK8-DWT10	1.64 (41.7)	0.80 (20.3)	0.40 (10.2)	15/16
	3/4	-U-ZK8-DWT12	1.69 (42.9)			
3/4	1	-U-ZK12-DWT16	1.78 (45.)	0.94 (23.9)	0.62 (15.7)	1 1/4
1	1 1/4	-U-ZK16-DWT20	1.80 (45.7)	0.94 (23.9)	0.87 (22.1)	1 9/16

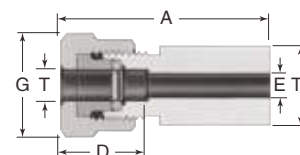

螺母

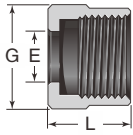

卡套管外径 in.	订购号	螺纹 尺寸	尺寸, in. (mm)		
			E	L	G
1/8	-ZKM2	3/8-20 UN	0.13 (3.3)	0.41 (10.4)	9/16
1/4	-ZKM4	1/2-20 UNF	0.26 (6.6)	0.53 (13.5)	11/16
3/8	-ZKM6	5/8-20 UN	0.38 (9.6)	0.62 (15.7)	13/16
1/2	-ZKM8	3/4-20 UNEF	0.51 (13.0)	0.62 (15.7)	15/16
5/8	-ZKM10	15/16-20 UNEF	0.63 (16.0)	0.62 (15.7)	1 1/8
3/4	-ZKM12	1 1/16-20 UN	0.76 (19.3)	0.72 (18.3)	1 1/4
1	-ZKM16	1 3/8-20 UN	1.01 (25.6)	0.72 (18.3)	1 9/16

O 型圈



卡套管外径 in.	统一尺寸号	订购号
1/8	006	OR-006
1/4	010	OR-010
3/8	012	OR-012
1/2	014	OR-014
5/8	114	OR-114
3/4	116	OR-116
1	120	OR-120

北京尼克福斯阀门科技有限责任公司

地址:北京市大兴区丽园路港悦大厦7号楼1101
电话:86-010-66117795
传真:86-010-63733307 网址:www.nikfus.cn
邮编:100071 邮箱:sale1@nikfus.com

沧州尼克福斯仪表有限公司

地址:河北省沧州市南皮工业区
手机:13811443727 (微信同号)
邮编:061599 网址:www.nikfus.cn